

# TechGrip®-Handlauf

## - Handrail

### Typenbeschreibung General Specification

Handlauf-Typ:  
Type of Handrail:

**Gelsdorf**

GmbH & Co. KG.

Max-Planck-Str. 2-6

53501 Grafschaft-Gelsdorf

**BT. 11-F ( 80/28 )**

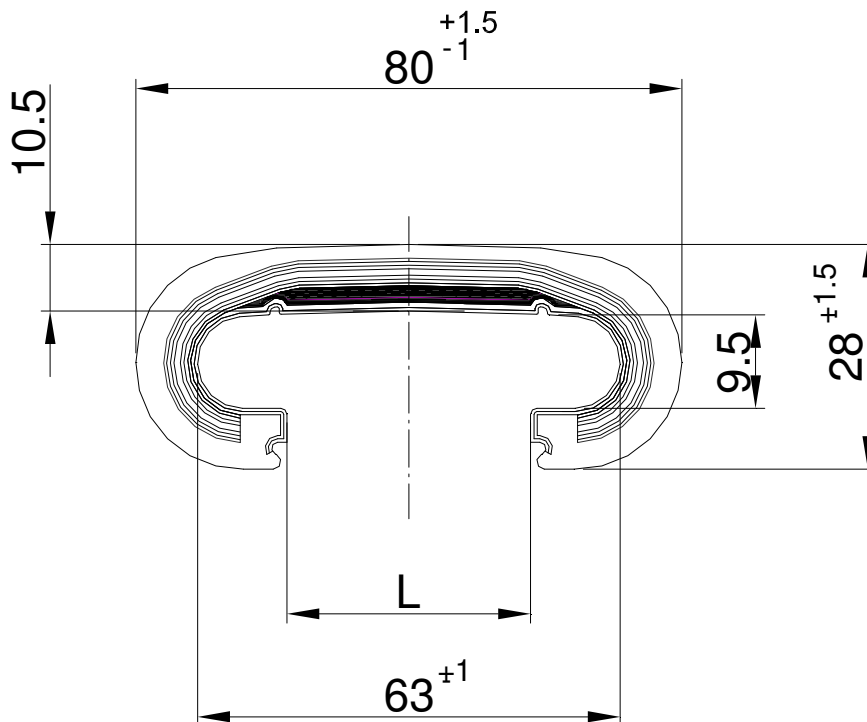

HL Typ Type	Fahrtreppen Fahrsteige Escalators Walkways	Lippenmaß [ L ]	Reißfestigkeit Handlauf Breaking Strength (Handrail)	Reißfestigkeit Verbindung Breaking strength (Factory Splice)
BT. 11-F	Schindler LÖHER Montgomery Mitsubishi	39 – 42 mm	min. 33 kN	min. 28 kN
<b>Qualität:</b>	<b>Rubber:</b>	SBR mit Schutzwachs / with protection wax		
<b>Härte: [Sh °A] :</b>	<b>Hardness:</b>	75 +/- 5		
<b>Oberfläche:</b>	<b>Surface:</b>	Seidenmatt / silky	Hochglänzend / glossy	
<b>Farbe:</b>	<b>Colour:</b>	SBR schwarz / black	EPDM farbig / coloured	
<b>Umlage:</b>	<b>Slider:</b>	Polyamid ( PA )		
		Polyester ( PET )		
		Baumwolle cotton		
<b>Treiblage (Option):</b> <b>Traction Zone:</b>		Baumwolle cotton		